

Amphe-Lite™ D38999 Series III Derivative



LIGHT-WEIGHT COMMERCIAL 38999 DERIVATIVE PERFECT FOR COMMUNICATIONS EQUIPMENT IN HARSH ENVIRONMENTS

Amphenol's Amphe-Lite™ connectors are light-weight commercial 38999s that offer the highest performance capabilities for harsh environments, including communication towers and equipment, manufacturing process control and medical equipment.

APPLICATIONS

- Medical equipment
- Process control
- Communications equipment
- Industrial

FEATURES

HIGH-RELIABILITY

Amphe-Lite connectors perform flawlessly under wide temperature ranges and in high vibrations and are resistant to a vast array of contaminants. Visual confirmation of mating is accomplished by the plug coupling nut covering a red band on the mating shell.

OUTSTANDING EMI-SHIELDING PROTECTION

These connectors provide excellent signal integrity due to the shielded mating system that utilizes 360-degree shell grounding fingers, providing protection of up to 50 dB minimum - 100Mhz to 10GHz.

OPERATES AT EXTREME TEMPERATURES

These connectors will operate in temperatures from -67°F up to 320°F (-55°C up to +150°C).

HIGH-DENSITY CONNECTORS

If space is at a premium, Amphe-Lite offers up to 128 contacts per connector. Ideally suited for digital electronics used on fly-by wire aircraft, advanced robotics, and critical industrial equipment.

SELF-LOCKING CONNECTOR SYSTEMS

Self-locking coupling nuts and self-locking endbell accessory hardware provide the best performance for threaded connectors in high-vibration applications.

CONTACT PROTECTION

Amphe-Lite connectors are designed to be scoop-proof. Pin contacts are recessed to prevent contact damage and contact shorting when connector halves are mated.

APPROVALS

Amphe-Lite is UL-recognized, File E115497

RoHS Compliant

TECHNICAL
SPECIFICATIONS**MATERIALS AND FINISHES**

Shell & Plating	Composite, electroless nickel-plated and unplated (RoHS)
Contacts	Copper alloy
Plating	Gold-plated, 50 microinches per MIL-G-45204 type II, grade C, class I
Insulator	Hard dielectric wafer which contains tines for high-reliability retention of crimp contacts
Grommet & Seals	Fluorinated is standard or dimethyl silicone rubber elastomer
Grounding Springs	Beryllium copper (grounded plug only)

ELECTRICAL DATA

Contact Sizes 22D, 20, 16, 12, 10 and 8

Operating Voltage & Test Voltage	TEST VOLTAGES	SERVICE RATING			
		N	M	I	II
	Sea Level	1000	1300	1800	2300
100,000 Feet	200	200	200	200	

Current Rating by Contact Size & Wire Accommodation (Test Amps)

WIRE SIZE	22D	20	16	12	10	8
28	1.5	-	-	-	-	-
26	2.0	-	-	-	-	-
24	3.0	3.0	-	-	-	-
22	5.0	5.0	-	-	-	-
20	-	7.5	7.5	-	-	-
18	-	-	10.0	-	-	-
16	-	-	13.0	-	-	-
14	-	-	-	17.0	-	-
12	-	-	-	23.0	-	-
10	-	-	-	-	33.0	-
8	-	-	-	-	-	46.0

Contact Resistance of Mated Contacts End-to-End

CONTACT SIZE	MAXIMUM MILLIVOLT DROP
22D	73
20	55
16	49
12	42
10 (power)	33
8 (power)	26

Insulation Resistance 5,000 megohms minimum

MECHANICAL

Operating Temperature -55°C to +125°C (-67°F to +248°F)

Sealing Against sand, dust per MIL-STD-202 & ice resistance

Wire Sealing Range

CONTACT SIZE	MINIMUM INCHES	MAXIMUM INCHES	MINIMUM MM	MAXIMUM MM
22D	0.030	0.054	0.76	1.37
20	0.040	0.083	1.02	2.11
16	0.065	0.109	1.65	2.77
12	0.097	0.142	2.46	3.61
10	0.135	0.162	3.42	4.12
8 (power)	0.135	0.155	3.43	3.94
8 (coax)	0.135	0.155	3.43	3.94
8 (twinax)	0.124	0.134	3.15	3.40

TECHNICAL SPECIFICATIONS

Insulation Strip Length

CONTACT SIZE	STRIP LENGTH
22D	.125 (3.18)
20	.188 (4.77)
16	.188 (4.77)
12	.188 (4.77)
10	.335 (8.51)
8 (power)	.470 (11.94)

Mating Life 500 cycles minimum

Salt Spray Electroless nickel only: 2000 hours min.

Temp. Durability Unplated and electroless nickel: UL RTI rating is 105°C (221°F)

EMI-Shielding Effectiveness 100 MHz to 10 GHz - minimum attenuation of 50dB

Contact Type Crimp, fibre optic, coax, twinax, or printed circuit

Number of Circuits 2 to 128

Contact Insertion Rear-insertion/rear-extraction with simple plastic or high-quality metal hand tools.

Contact Retention

CONTACT	AXIAL LOAD NEWTONS ±10%	AXIAL LOAD POUNDS ±10%
22D	44	10
20	67	15
16	111	25
12	111	25
10	111	25
8	111	25

Polarization Five keyways with optional master keyway rotations (Note: insert and main keyways remain fixed)

Approvals UL E115497

All dimensions in inches (millimeters in parenthesis)

CROSS-SECTION

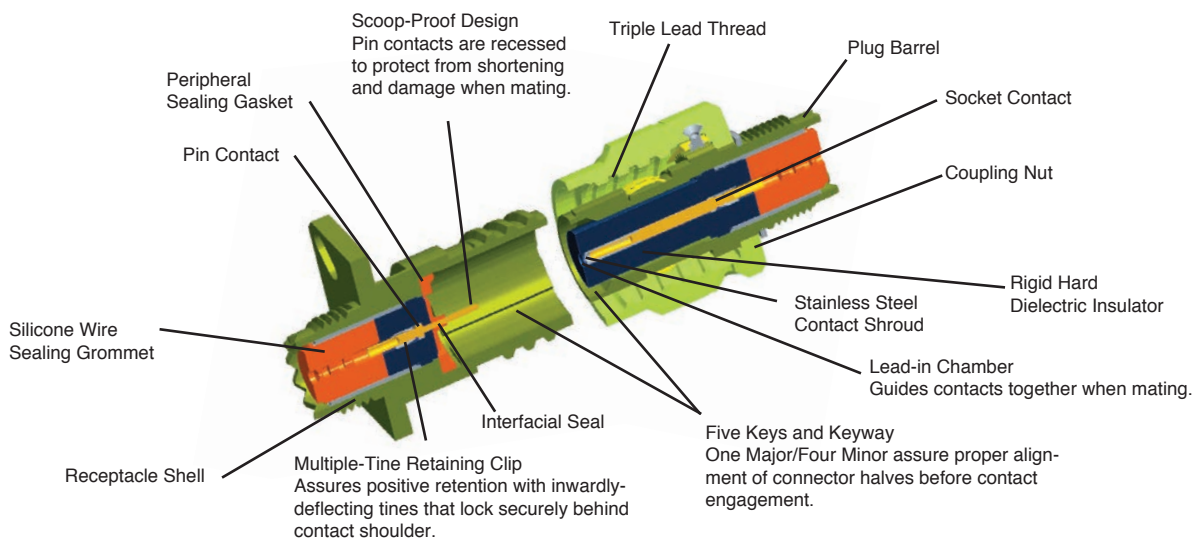

CREATE YOUR PART NUMBER

1	2	3	4	5	6
AL00	F	9-35	P	A	-LC
SHELL STYLE	FINISH	LAYOUT	CONTACT	POLARIZATION (OMIT FOR NORMAL)	MODIFIER

STEP 1: SELECT SHELL STYLE, PLUG OR RECEPTACLE

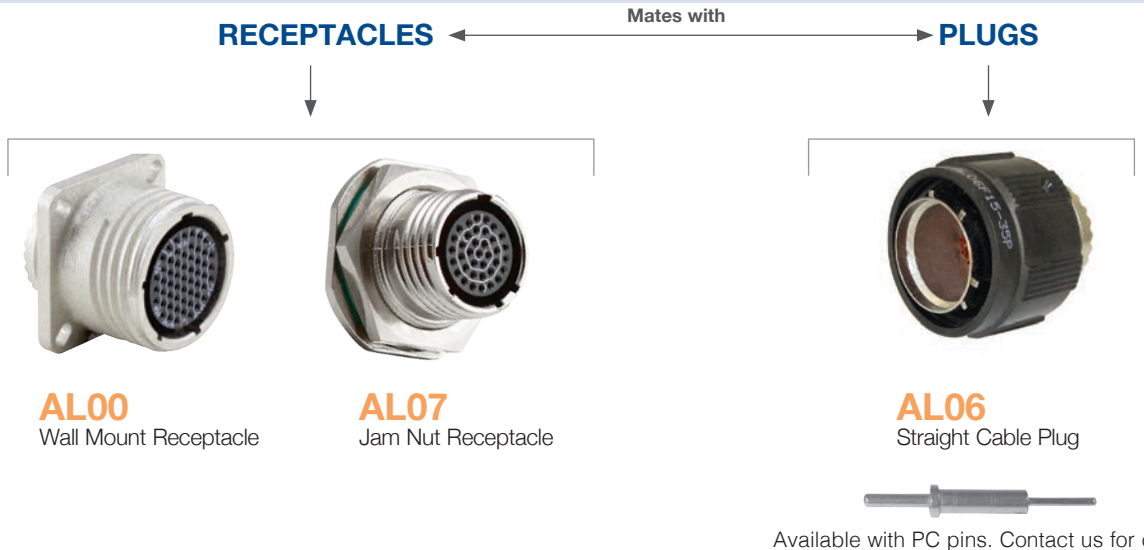

STEP 2: SELECT CLASS-SERVICE CLASS

(All classes are RoHS Compliant)

- F** = Electroless nickel-plated composite shells, with fluorinated silicone rubber components (*Brown-colored grommet*) (RoHS)
- FD** = Electroless nickel-plated composite shells, with dimethyl silicone rubber components. Not available on all inserts, see FD label†. (*Blue or red-colored insert*) (RoHS)
- U** = Black composite, unplated with fluorinated silicone rubber components. (*Brown-colored grommet*) (RoHS)
- UD** = Black composite, unplated with dimethyl silicone rubber components. Not available on all inserts, see UD label†. (*Blue or red-colored insert*) (RoHS)

STEP 3: SELECT LAYOUT

For listing by # of contacts, ⇌ see pages 240-243.

Layout Number	Service Rating	Contacts						
		Total Number	22D	20	16	12	10	8
9-35	M	6	6					
9-94	M	2		2				
9-98	I	3		3				
11-2†	I	2			2			
11-5	I	5		5				
11-35†	M	13	13					
11-98†	I	6		6				
11-99	I	7		7				
13-4†	I	4			4			
13-8†	I	8		8				
13-13†	I, FIBRE OPTIC	4			2	2		
13-35	M	22	22					
13-71†	I	2				2		
13-98†	I	10		10				
15-AC†	M	26	24		2			
15-5	II	5			5			
15-15	I	15		14	1			
15-18	I	18		18				
15-19†	I	19		19				
15-35†	M	37	37					
15-97	I	12		8	4			
17-2	M	39	38					1**
17-6	I	6				6		
17-8†	II	8		8				
17-22	COAX	4					2	2*
17-26†	I	26		26				
17-31	M	19	4	11	4			
17-35	M	55	55					
17-99	I	23		21	2			
19-11	II	11			11			
19-31	M	15	12			1		2
19-32	I	32		32				
19-35	M	66	66					
21-11	I	11				11		
21-16	II	16			16			
21-35†	M	79	79					
21-39	I	39		37	2			
21-41	I	41		41				
21-75	M	4						4*
23-6	M	6						6**
23-21	II	21			21			
23-35	M	100	100					
23-53	I	53		53				
23-54	M	53	40		9	4		
23-55	I	55		55				
25-4	I	56		48	8			
25-7	TWINAX	99	97					2**
25-8	TWINAX	8						8**
25-11	N	11		2			9	
25-17	M	42	36					6**
25-19	I	19				19		
25-20	N	30		10	13		4	3**
25-24	I	24			12	12		
25-26	I	25		16		5		4*
25-29	I	29			29			
25-35	M	128	128					
25-37	I	37			37			
25-43	I	43		23	20			
25-46	I	46		40	4			2*
25-61	I	61		61				

Note: Propriety connector 21-75 is supplied with size 8 Coax

*Coax **Twinax Contact us for more information.

† UD/FD-Type Insert Tooled

STEP 4: SELECT CONTACT

P = Pin S = Socket

STEP 5: SELECT POLARIZATION

N = Normal Standard (Omit for normal)

A = Highly-Popular sizes 11, 13, & 17 only

B = Limited Availability sizes 11, 13, & 17 only

C = Check for Availability sizes 13, & 17 only

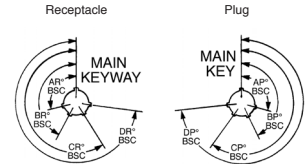

Shell Size		Minor Key Locations				
		AR & AP	BR & BP	CR & CP	DR & DP	
A	N	105	140	215	265	
	A	102	132	248	320	
	B	80	118	230	312	
	C	35	140	205	275	
	D	64	155	234	304	
	E	91	131	197	240	
B	N	95	141	208	236	
	A	113	156	182	292	
	D	B	90	145	195	252
		C	53	156	220	255
	D	119	146	176	298	
	E	51	141	184	242	
E	N	80	142	196	293	
	F	A	135	170	200	310
		B	49	169	200	244
		C	66	140	200	257
		D	62	145	180	280
		E	79	153	197	272
G	N	80	142	196	293	
	A	135	170	200	310	
J	B	49	169	200	244	
	C	66	140	200	257	
	D	62	145	180	280	
	E	79	153	197	272	

STEP 6: MODIFIER

Omit for standard contacts

LC = No contacts, sealing plugs or tools supplied

(P.O. must state Less Contacts.) LC is not marked on parts

NMG = Non-magnetic (Please contact us for availability)

LAYOUT BY NUMBER OF CONTACTS

View of Mating Face of Pin Insert



CONTACTS	2			3	4		
LAYOUT # OF CONTACTS SERVICE RATING	9-94 2-#20 M	11-2† 2-#16 I	13-71† 2-#12 I	9-98 3-#20 I	13-4† 4-#16 I	13-13† 2-#16, 2-#12 I, FIBER OPTIC	17-22 2-#12*, 2-#8* COAX
CONTACTS	4		5	6			
LAYOUT # OF CONTACTS SERVICE RATING	21-75 4-#8* M		11-5 5-#20 I	15-5 5-#16 II			9-35 6-#22D M
LAYOUT # OF CONTACTS SERVICE RATING	23-6 6-#8** M		11-99 7-#20 I	13-8† 8-#20 I	17-8† 8-#16 II		
LAYOUT # OF CONTACTS SERVICE RATING	25-8 8-#8** TWINAX						
CONTACTS	10	11					
LAYOUT # OF CONTACTS SERVICE RATING	13-98† 10-#20 I	19-11 11-#16 II					
LAYOUT # OF CONTACTS SERVICE RATING	21-11 11-#12 I		25-11 2-#20, 9-#10 N				

*Coax **Twinax † UD/FD-Type Insert Toolled Contact us for more information.

LAYOUT BY NUMBER OF CONTACTS

View of Mating Face of Pin Insert



CONTACTS	12	13	15	
LAYOUT # OF CONTACTS SERVICE RATING	15-97 8-#20, 4-#16 I	11-35† 13-#22D M	15-15 14-#20, 1-#16 I	19-31 12-#22D, 1-#12, 2-#8* M
CONTACTS	16	18	19	
LAYOUT # OF CONTACTS SERVICE RATING	21-16 16-#16 II	15-18 18-#20 I	15-19† 19-#20 I	17-31 4-#22D, 11-#20, 4-#16 M
CONTACTS	19	21	22	23
LAYOUT # OF CONTACTS SERVICE RATING	25-19 19-#12 I	23-21 21-#16 II	13-35 22-#22D M	17-99 21-#20, 2-#16 I
CONTACTS	24	25	26	
LAYOUT # OF CONTACTS SERVICE RATING	25-24 12-#16, 12-#12 I	25-26 16-#20, 5-#12, 4-#8* I	15-AC† 24-#22D, 2-#16 M	17-26† 26-#20 I

*Coax **Twinax † UD/FD-Type Insert Toolled Contact us for more information.

LAYOUT BY NUMBER OF CONTACTS

View of Mating Face of Pin Insert



CONTACTS 29 30 32 37

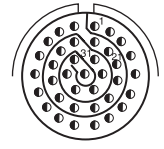
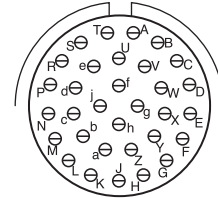
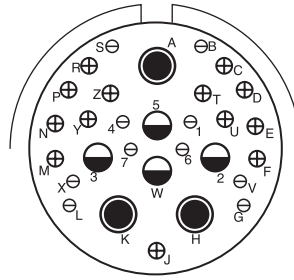
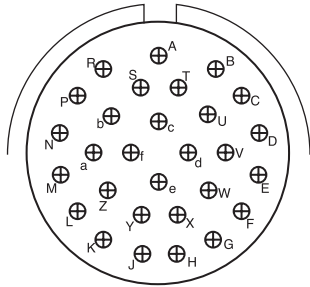

LAYOUT
OF CONTACTS
SERVICE RATING

25-29
29-#16
I

25-20
10-#20, 13-#16, 4-#12*, 3-#8**

19-32
32-#20
I

15-35†
37-#22D
M

CONTACTS 37 39 41

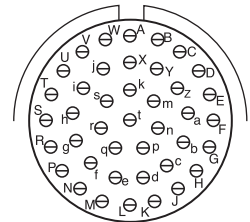
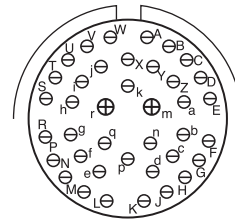
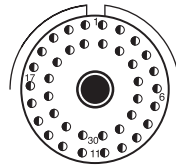
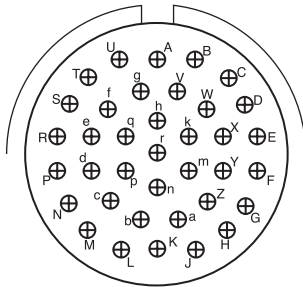

LAYOUT
OF CONTACTS
SERVICE RATING

25-37
37-#16
I

17-2
38-#22D, 1-#8**

21-39
37-#20; 2-#16
I

21-41
41-#20
I

CONTACTS 42 43 46

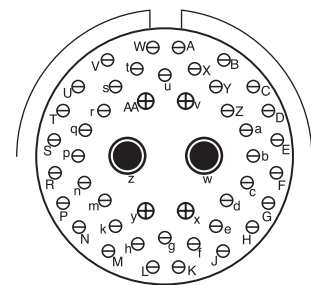
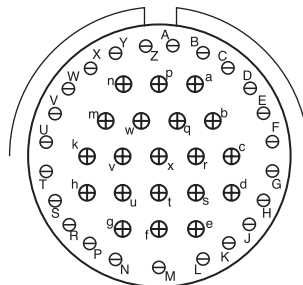
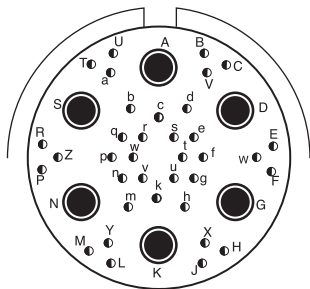

LAYOUT
OF CONTACTS
SERVICE RATING

25-17
36-#22D, 6-#8**
M

25-43
23-#20, 20-#16
I

25-46
40-#20, 4-#16, 2-#8*
I

*Coax **Twinax † UD/FD-Type Insert Toolled Contact us for more information.

LAYOUT BY NUMBER OF CONTACTS

View of Mating Face of Pin Insert



CONTACTS 53 55

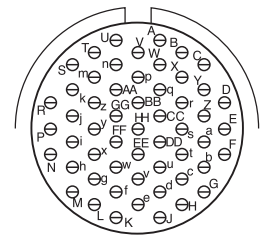
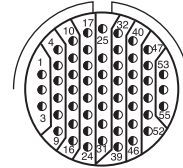
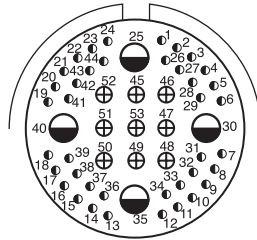
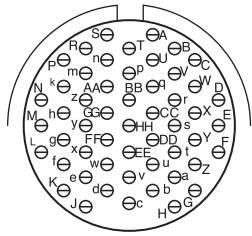

LAYOUT
OF CONTACTS
SERVICE RATING

23-53
53-#20
I

23-54
40-#22D, 9-#16, 4-#12
M

17-35
55-#22D
M

23-55
55-#20
I

CONTACTS 56 61 66 79

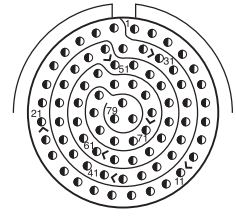
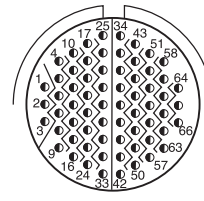
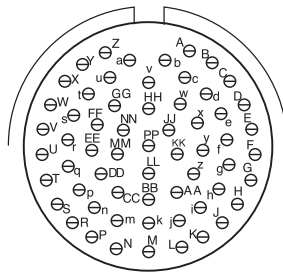
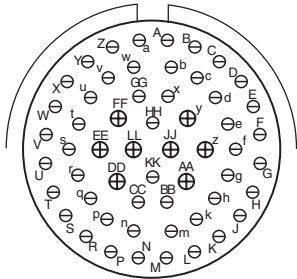

LAYOUT
OF CONTACTS
SERVICE RATING

25-4
48-#20, 8-#16
I

25-61
61-#20
I

19-35
66-#22D
M

21-35†
79-#22D
M

CONTACTS 99 100 128

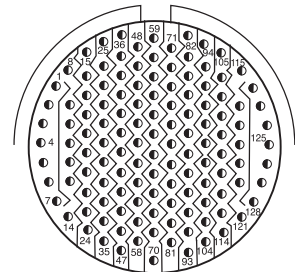
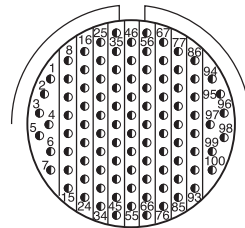
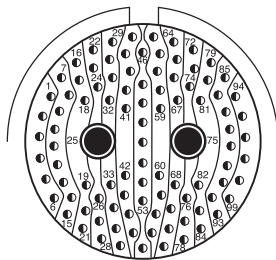

LAYOUT
OF CONTACTS
SERVICE RATING

25-7
97-#22D, 2-#8**
TWINAX

23-35
100-#22D
M

25-35
128-#22D
M

*Coax **Twinax † UD/FD-Type Insert Toolled Contact us for more information.

CONTACTS

PINS

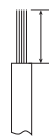

Insert head first,
Trim excess.

CONTACT SIZE	WIRE SIZE AWG	PIN CONTACT PART NUMBER	COLOR BANDS			WIRE STRIP LENGTHS	WIRE RANGE		WIRE HOLE FILLER	COLOR
			1	2	3		MIN.	MAX.		
22D	22,24,26 & 28	M39029/58-360	Orange	Blue	Black	.125 (3.18)	.030 (0.76)	.054 (1.37)	MS27488-22-2	Black
		M39029/107-620#	Blue	Red	Black					
20	20,22 & 24	M39029/58-363	Orange	Blue	Orange	.188 (4.77)	.040 (1.02)	.083 (2.11)	MS27488-20-2	Red
		M39029/107-621#	Blue	Red	Brown					
16	16,18 & 20	M39029/58-364	Orange	Blue	Yellow	.188 (4.77)	.065 (1.65)	.109 (2.77)	MS27488-16-2	Blue
		M39029/107-622#	Blue	Red	Red					
12	12 & 14	M39029/58-365	Orange	Blue	Green	.188 (4.77)	.097 (2.46)	.142 (3.61)	MS27488-12-2	Yellow
		M39029/107-623#	Blue	Red	Orange					
10	10 & 12	M39029/58-528	Green	Red	Gray	.335 (8.51)	.135 (3.42)	.162 (4.12)	M85049/81-10	Green
8	Coax*	M39029/60-367	Orange	Blue	Violet	Detailed instructions included with contacts	.135 (3.42)	.162 (4.12)	MS27488-8-3	Red
8	Twinax**	M39029/90-529	Green	Red	White		.124 (3.15)	.134 (3.40)	MS27488-8-3	Red
8 Power	8	10-497448-075	-	-	-	.470 (11.94)	.135 (3.42)	.162 (4.12)	MS27488-8-3	Red
8 Power	10	10-497448-095	-	-	-	.470 (11.94)	.135 (3.42)	.162 (4.12)	MS27488-8-3	Red

#1500-Mating Cycle Contacts *Coax **Twinax contact us for details. For Fibre Optic Contacts, please contact us.

SOCKETS

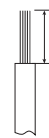

Insert head first,
Trim excess.

CONTACT SIZE	WIRE SIZE AWG	PIN CONTACT PART NUMBER	COLOR BANDS			WIRE STRIP LENGTHS	WIRE RANGE		WIRE HOLE FILLER	COLOR
			1	2	3		MIN.	MAX.		
22D	22,24,26 & 28	M39029/56-348	Orange	Yellow	Gray	.125 (3.18)	.030 (0.76)	.054 (1.37)	MS27488-22-2	Black
		M39029/106-614#	Blue	Brown	Yellow					
20	20, 22 & 24	M39029/56-351	Orange	Green	Brown	.188 (4.77)	.040 (1.02)	.083 (2.11)	MS27488-20-2	Red
		M39029/106-615#	Blue	Brown	Green					
16	16,18 & 20	M39029/56-352	Orange	Green	Red	.188 (4.77)	.065 (1.65)	.109 (2.77)	MS27488-16-2	Blue
		M39029/106-616#	Blue	Brown	Blue					
12	12 & 14	M39029/56-353	Orange	Green	Orange	.188 (4.77)	.097 (2.46)	.142 (3.61)	MS27488-12-2	Yellow
		M39029/106-617#	Blue	Brown	Violet					
10	10 & 12	M39029/56-527	Green	Red	Violet	.355 (8.51) Detailed instructions included with contacts	.135 (3.42)	.162 (4.12)	M85049/81-10	Green
8	Coax*	M39029/59-366	Orange	Blue	Blue		.135 (3.42)	.162 (4.12)	MS27488-8-3	Red
8	Twinax**	M39029/91-530	Green	Orange	Black		.124 (3.15)	.134 (3.40)	MS27488-8-3	Red
8 Power	8	10-497446-075	-	-	-	.470 (11.94)	.135 (3.42)	.162 (4.12)	MS27488-8-3	Red
8 Power	10	10-497446-095	-	-	-	.470 (11.94)	.135 (3.42)	.162 (4.12)	MS27488-8-3	Red

#1500-Mating Cycle Contacts *Coax **Twinax contact us for details. For Fibre Optic Contacts, please contact us.

All dimensions in inches (millimeters in parenthesis)

PINS

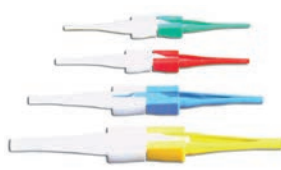

CONTACT SIZE	HAND-CRIMP TOOL	POWER-CRIMP TOOL	TURRET HEADS	USE LOCATOR COLOR	PLASTIC INSERTION/EXTRACTION TOOL	INSERTION TIP COLOR	EXTRACTION TIP COLOR	METAL INSERTION TOOL	COLOR BAND	METAL EXTRACTION TOOL	COLOR BAND	
											1	2
22D	M22520/2-01	WA22††	M22520/2-09	-	M81969/14-01	Green	White	MS27495A22M	Black	MS27495R22M	Black	White
20	M22520/1-01	WA27F††	M22520/1-04	Red	M81969/14-10	Red	Orange	MS27495A20	Red	MS27495R20	Red	White
16	M22520/1-01	WA27F††	M22520/1-04	Blue	M81969/14-03	Blue	White	MS27495A16	Blue	MS27495R16	Blue	White
12	M22520/1-01	WA27F††	M22520/1-04	Yellow	M81969/14-04	Yellow	White	DAK95-12B	-	DRK95-12B	-	-
10	TP-201423 or 1716P-1	-	-	-	M81969/14-05	Gray	White	M81969/8-11	Green	M81969/8-12	Green	White
8 Coax	M22520/2-01 M22520/5-01	WA22†† HX23	M22520/2-31 (inner) M22520/5-05 (outer)	-	M81969/14-12	Green		-	-	DRK264-8	-	-
8 Twinax	M22520/2-01 M22520/5-01	WA22 HX23	K709 (inner) Y631 (outer)	-	M81969/14-12	Green		M81969/46-06	Red	M81969/46-12	-	-
8 8 AWG Power	-	400B-1	414DA-8N (Die) 4691 (positioner)	-	M81969/14-12 (extraction only)	-	Green	-	-	DRK264-8	-	-
8 10 AWG Power	M3SP-6	400B-1	414DA-10N (Die) 4691 (positioner)	-	M81969/14-12 (extraction only)	-	Green	-	-	DRK264-8	-	-

†† Contact us for more tool accessories.

SOCKETS

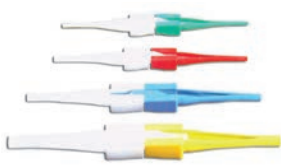

CONTACT SIZE	HAND-CRIMP TOOL	POWER-CRIMP TOOL	TURRET HEADS	USE LOCATOR COLOR	PLASTIC INSERTION/EXTRACTION TOOL	INSERTION TIP COLOR	EXTRACTION TIP COLOR	METAL INSERTION TOOL	COLOR BAND	METAL EXTRACTION TOOL	COLOR BAND	
											1	2
22D	M22520/2-01	WA22††	M22520/2-09	-	M81969/14-01	Green	White	MS27495A22M	Black	MS27495R22M	Black	White
20	M22520/1-01	WA27F††	M22520/1-04	Red	M81969/14-10	Red	Orange	MS27495A20	Red	MS27495R20	Red	White
16	M22520/1-01	WA27F††	M22520/1-04	Blue	M81969/14-03	Blue	White	MS27495A16	Blue	MS27495R16	Blue	White
12	M22520/1-01	WA27F††	M22520/1-04	Yellow	M81969/14-04	Yellow	White	DAK95-12B	-	DRK95-12B	-	-
10	TP-201423 or 1716P-1	-	-	-	M81969/14-05	Gray	White	M81969/8-11	Green	M81969/8-12	Green	White
8 Coax	M22520/2-01 M22520/5-01	WA22†† HX23	M22520/2-31 (inner) M22520/5-05 (outer)	-	M81969/14-12	Green		-	-	DRK264-8	-	-
8 Twinax	M22520/2-01 M22520/5-01	WA22 HX23	K709 (inner) Y631 (outer)	-	M81969/14-12	Green		M81969/46-06	Red	M81969/46-12	-	-
8 8 AWG Power	-	400B-1	414DA-8N (Die) 4691 (positioner)	-	M81969/14-12 (extraction only)	-	Green	-	-	DRK264-8	-	-
8 10 AWG Power	M3SP-6	400B-1	414DA-10N (Die) 4691 (positioner)	-	M81969/14-12 (extraction only)	-	Green	-	-	DRK264-8	-	-

†† Contact us for more tool accessories.

CONTACTS

COAX CONTACTS



M22520/5-01

Crimp Dies

COAX CONTACT SIZE	CABLE TYPE	CONTACT PART NUMBER		CRIMPING TOOLS	
		PIN	SOCKET	INNER CONTACT	CRIMP FERRULE
16	RG-178B/U, RG-196A/U	21-033122-564 (M39029/76-425)	21-033123-564 (M39029/77-429)	M22520/2-01 w/ Positioner M22522/2-35 or w/ Daniels Positioner K532	M22520/4-01 w/ Positioner M22520/4-02
	RG-174A/U, RG-188A/U, RG-161/U, RG-187A/U, RG-316/U, RG-179B/U	21-033122-563 (M39029/76-424)	21-033123-563 (M39029/77-428)		
12	RG-180B/U, RG-195A/U	21-033122-546 (M39029/28-211)	21-033123-546 (M39029/75-416)	M22520/2-01 w/ Positioner M22520/2-34 or w/ Daniels Positioner K323	M22520/31-01 w/ Positioner M22520/31-02 or Daniels GS-200 Tool w/ Positioner G2P330
		21-033122-541 (M39029/28-409)	21-033123-541 (M39029/75-417)		
8	RG-187A/U, RG-179B/U, RG-174A/U, RG-188A/U, RG-316/U, RG-161/U	21-033102-023	21-033101-023	M22520/2-01 w/ Positioner M22520/2-31 or Solder	M22520/5-01 w/ die set M22520/5-03 (A) or M22520/5-08 (A) M22520/5-35 (B) or M22520/10-01 w/ die set M22520/10-05 (A)
	RG-142B/U, RG-223/U	21-033102-024	21-033101-024		M22520/5-01 w/ die set M22520/5-05 (A) or M22520/5-19 (A) or M22520/10-01 w/ die set M22520/10-07 (A)
	RG-180B/U, RG-195A/U	21-033102-021 (M39029/60-367)	21-033101-021 (M39029/59-366)		M22520/5-01 w/ die set M22520/5-05 (B) or M22520/5-41 (B) or M22520/10-01 w/ die set M22520/10-07 (B)
	RG-400	21-033102-027	21-033101-027	M22520/2-01 w/ Positioner M22520/2-10	M22520/5-01 w/ die set M22520/5-45 (A)
	RG-58 (M17/155-00001)	21-033102-029	21-033101-029	Solder	M22520/5-01 w/ die set M22520/5-05 (B)

PRINTED CIRCUIT BOARD CONTACTS - PIN

PCB PIN CONTACTS	SIZE	TAIL DIAMETER +/- .001	CONTACT STICKOUT MAX./MIN.				
			D38999/20 TVP00	TVP02	D38999/26 TV06	D38999/24 TV07	
						METAL	COMPOSITE
10-407552-015	22D	0.019	.335 / .280	.555 / .500	.360 / .305	.329 / .279	.286 / .236
10-407552-055	22D	0.019	.224 / .169	.444 / .389	.249 / .194	.218 / .168	.175 / .125
10-407552-085	22D	0.019	.060 / .010	.280 / .230	.085 / .035	.054 / .009	.011 / NS
10-407552-115	22D	0.019	.002 / NS	.222 / NS	.023 / NS	NS	NS
10-497640-015	20	0.019	.348 / .298	.568 / .518	.373 / .323	.342 / .297	.299 / .254
10-497640-025	20	0.019	.213 / .163	.433 / .383	.238 / .188	.207 / .162	.164 / .119
10-497640-045	20	0.019	NS	NS	NS	NS	NS
10-497596-015	20	0.025	.058 / .012	.278 / .232	.083 / .037	.052 / .011	.009 / .044
10-497596-025	20	0.025	.148 / .102	.368 / .322	.173 / .127	.142 / .101	.099 / .058
10-497596-035	20	0.025	.229 / .183	.449 / .403	.254 / .208	.223 / .182	.180 / .058
10-497596-055	20	0.025	.346 / .300	.566 / .520	.371 / .325	.340 / .299	.297 / .256
10-497695-015	16	0.040	.255 / .205	.475 / .425	.280 / .230	.249 / .204	.206 / .161
10-497630-035	16	0.062	.060 / .010	.280 / .230	.085 / .035	.054 / .009	.011 / NS
10-497630-055	16	0.062	.228 / .178	.460 / .375	.253 / .203	.244 / .177	.201 / .190
10-597502-015	12	0.081	.228 / .178	.448 / .398	.252 / .203	.222 / .177	.179 / .134

Standard PC tail used

All dimensions in inches (millimeters in parenthesis)

WIRE HOLE FILLER



WIRE STRIP LENGTH

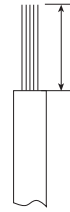

WIRE SEALING RANGE



COAX CONTACT SIZE	INSTALLATION TOOLS		WIRE STRIP LENGTHS	WIRE SEALING RANGE	
	INSERTION	REMOVAL		MIN.	MAX.
16	M81969/8-07 or M81969/14-03	M81969/8-08 or M81969/14-03	Contact us for details	.065 (1.65)	.109 (2.77)
12	M81969/8-09 or M81969/14-04	M81969/8-10 or M81969/14-04	Contact us for details	.097 (2.46)	.142 (3.61)
8	Hand-insertion	M81969/14-012 or DRK264-8 or 11-9170	Contact us for details	.135 (3.43)	.155 (3.94)

PRINTED CIRCUIT BOARD CONTACTS - SOCKET

PCB PIN CONTACTS	SIZE	TAIL DIAMETER +/- .001	CONTACT STICKOUT MAX./MIN.				
			D38999/20 TVP00	TVP02	D38999/26 TV06	D38999/24 TV07	
						METAL	COMPOSITE
10-497623-015	22D	0.019	.291 / .226	.511 / .446	.316 / .251	.285 / .222	.242 / .182
10-497623-335	22D	0.019	.242 / .181	.471 / .399	.267 / .202	.258 / .180	.215 / .155
10-497623-025	22D	0.019	.868 / .803	1.088 / 1.023	.893 / .828	.862 / .802	.819 / .759
10-497623-035	22D	0.019	.348 / .283	.568 / .503	.373 / .308	.342 / .282	.299 / .239
10-497623-045	22D	0.019	.208 / .143	.428 / .363	.233 / .168	.202 / .142	.159 / .099
10-497623-075	22D	0.019	.146 / .081	.366 / .301	.171 / .106	.140 / .080	.097 / .037
10-497623-145	22D	0.019	.609 / .539	.829 / .759	.634 / .564	.603 / .538	.560 / .495
10-497623-155	22D	0.019	.423 / .358	.643 / .578	.448 / .383	.417 / .357	.374 / .314
10-497643-015	20	0.019	.348 / .294	.568 / .514	.373 / .319	.342 / .293	.299 / .250
10-497643-025	20	0.019	.213 / .159	.433 / .379	.238 / .184	.207 / .158	.164 / .115
10-497643-035	20	0.019	.555 / .501	.775 / .721	.580 / .526	.549 / .500	.506 / .457
10-497650-015	16	0.040	.255 / .201	.475 / .421	.280 / .226	.249 / .200	.206 / .157
10-597503-015	12	0.081	.184 / .130	.404 / .350	.209 / .155	.178 / .129	.135 / .086

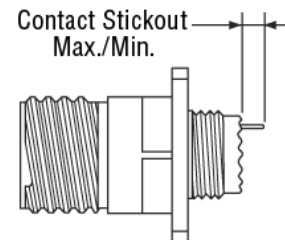

Standard PC tail used

All dimensions in inches (millimeters in parenthesis)

DIMENSIONS

RECEPTACLE - WALL MOUNTING

AL00

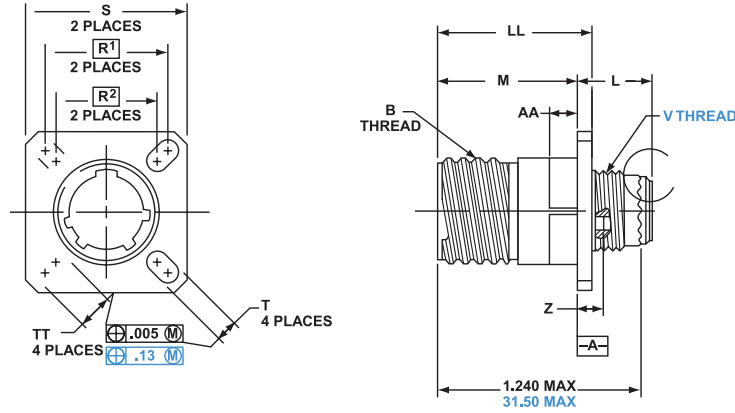

Shell Size	B Thread Class 2A 1.0P-0.3L -TS (Plated)	L Max.	M +.000/- .005 (+.000/- .13)	R1	R2	S Max.	T +.008/- .006 (+.20/- .13)	V Thread Metric	Z Max.	AA Max. Panel Thickness	LL +/- .005 (+/- .13)	TT +.008/- .006 (+.20/- .13)
9	.6250	.514 (13.06)	.775 (19.69)	.719 (18.26)	.594 (15.09)	.948 (24.10)	.128 (3.25)	M12X1-6g	.198 (5.03)	.234 (5.94)	.913 (23.19)	.216 (5.49)
11	.7500	.514 (13.06)	.775 (19.69)	.812 (20.62)	.719 (18.26)	1.043 (26.50)	.128 (3.25)	M15X1-6g	.198 (5.03)	.234 (5.94)	.913 (23.19)	.194 (4.93)
13	.8750	.514 (13.06)	.775 (19.69)	.906 (23.01)	.812 (20.62)	1.137 (28.90)	.128 (3.25)	M18X1-6g	.198 (5.03)	.234 (5.94)	.913 (23.19)	.194 (4.93)
15	1.0000	.514 (13.06)	.775 (19.69)	.969 (24.61)	.906 (23.01)	1.232 (31.30)	.128 (3.25)	M22X1-6g	.198 (5.03)	.234 (5.94)	.913 (23.19)	.173 (4.39)
17	1.1875	.514 (13.06)	.775 (19.69)	1.062 (26.97)	.969 (24.61)	1.323 (33.70)	.128 (3.25)	M25X1-6g	.198 (5.03)	.234 (5.94)	.913 (23.19)	.194 (4.93)
19	1.2500	.514 (13.06)	.775 (19.69)	1.156 (29.36)	1.062 (26.97)	1.449 (36.90)	.128 (3.25)	M28X1-6g	.198 (5.03)	.234 (5.94)	.913 (23.19)	.194 (4.93)
21	1.3750	.545 (13.84)	.745 (18.92)	1.250 (31.75)	1.156 (29.36)	1.575 (40.10)	.128 (3.25)	M31X1-6g	.228 (5.79)	.204 (5.18)	.911 (23.14)	.194 (4.93)
23	1.5000	.545 (13.84)	.745 (18.92)	1.375 (34.93)	1.250 (31.75)	1.701 (43.30)	.154 (3.91)	M34X1-6g	.228 (5.79)	.204 (5.18)	.911 (23.14)	.242 (6.15)
25	1.6250	.545 (13.84)	.745 (18.92)	1.500 (38.10)	1.375 (34.93)	1.823 (46.40)	.154 (3.91)	M37X1-6g	.228 (5.79)	.204 (5.18)	.911 (23.14)	.242 (6.15)

RECEPTACLE - JAM NUT

AL07

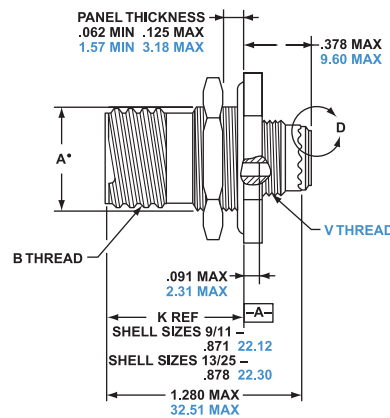

SHELL SIZE	A +.000/- .010 (+.00/- .25)	B THREAD CLASS 2A 0.1P-0.3L-TS (PLATED)	C MAX.	H HEX +.017/- .016 (+.43/- .41)	S +/- .010 (+/- .25)	T +.010/- .000 (+.25/- .00)	V THREAD METRIC
9	.669 (16.99)	0.6250	1.199 (30.45)	0.875 (22.23)	1.062 (26.97)	0.697 (17.70)	M12X1-6g
11	0.769 (19.53)	0.7500	1.386 (35.20)	1.062 (27.00)	1.250 (31.75)	0.822 (20.88)	M15X1-6g
13	0.955 (24.26)	0.8750	1.511 (38.38)	1.250 (30.18)	1.375 (34.93)	1.007 (25.58)	M18X1-6g
15	1.084 (27.53)	1.0000	1.636 (41.55)	1.375 (33.32)	1.500 (38.10)	1.134 (28.80)	M22X1-6g
17	1.208 (30.68)	1.1875	1.761 (44.73)	1.438 (36.53)	1.625 (41.28)	1.259 (31.98)	M25X1-6g
19	1.333 (33.86)	1.2500	1.949 (49.50)	1.562 (39.67)	1.812 (46.02)	1.384 (35.15)	M28X1-6g
21	1.459 (37.06)	1.3750	2.073 (52.65)	1.688 (42.80)	1.938 (49.23)	1.507 (38.28)	M31X1-6g
23	1.575 (40.01)	1.5000	2.199 (55.85)	1.812 (46.02)	2.062 (52.37)	1.634 (41.50)	M34X1-6g
25	1.709 (43.41)	1.6250	2.323 (59.00)	2.000 (50.80)	2.188 (55.58)	1.759 (44.68)	M37X1-6g

All dimensions in inches (millimeters in parenthesis)

PLUG - STRAIGHT

AL06

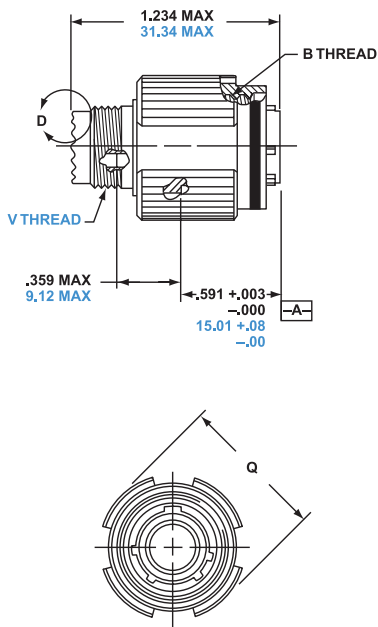

SHELL SIZE	B THREAD CLASS 2B 0.1P-0.3L-TS (PLATED)	Q DIAMETER MAX.	V THREAD METRIC
9	0.6250	.858 (21.8)	M12X1-6g
11	0.7500	.984 (25.0)	M15X1-6g
13	0.8750	1.157 (29.4)	M18X1-6g
15	1.0000	1.279 (32.5)	M22X1-6g
17	1.1875	1.405 (35.7)	M25X1-6g
19	1.2500	1.515 (38.5)	M28X1-6g
21	1.3750	1.641 (41.7)	M31X1-6g
23	1.5000	1.767 (44.9)	M34X1-6g
25	1.6250	1.889 (48.0)	M37X1-6g

PANEL CUTOUTS

WALL MOUNT RECEPTACLE

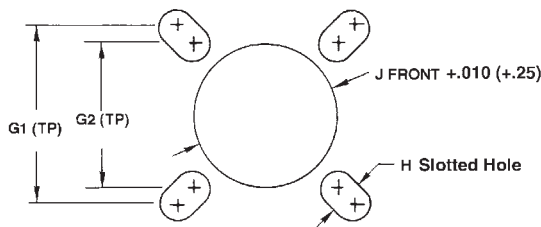

JAM NUT RECEPTACLE

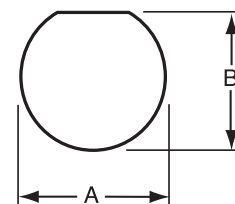

Shell Size		D38999/20 & TV/CTV Wall Mount				
D38999	TV/CTV	G1	G2	H Diameter +.005 (+.130) -.000 (.000)	Front Mount J Min.	Back Mount J Min.
A	9	.719 (18.26)	.59 (15.09)	.130 (3.25)	.516 (13.11)	.656 (16.66)
B	11	.81 (20.62)	.71 (18.26)	.130 (3.25)	.625 (15.88)	.796 (20.22)
C	13	.91 (23.01)	.81 (20.62)	.130 (3.25)	.750 (19.05)	.922 (23.42)
D	15	.97 (24.61)	.90 (23.01)	.130 (3.25)	.906 (23.01)	1.047 (26.59)
E	17	1.06 (26.97)	.96 (24.61)	.130 (3.25)	1.016 (25.81)	1.219 (30.96)
F	19	1.16 (29.36)	1.06 (26.97)	.130 (3.25)	1.141 (28.98)	1.297 (32.94)
G	21	1.25 (31.75)	1.15 (29.36)	.130 (3.25)	1.266 (32.16)	1.422 (36.12)
H	23	1.38 (34.93)	1.25 (31.75)	.155 (3.94)	1.375 (34.93)	1.547 (39.43)
J	25	1.50 (38.10)	1.37 (34.93)	.155 (3.94)	1.484 (37.69)	1.672 (42.47)

D38999/24 & TV/CTV Jam Nut	
A +.010 (+.025) -.000 (.000)	B +.000 (000) -.010 (-.025)
.693 (17.60)	.657 (16.70)
.825 (20.96)	.770 (19.59)
1.010 (25.65)	.955 (24.26)
1.135 (28.83)	1.085 (27.56)
1.260 (32.01)	1.210 (30.73)
1.385 (35.18)	1.335 (33.91)
1.510 (38.35)	1.460 (37.08)
1.635 (41.53)	1.585 (40.29)
1.760 (44.70)	1.710 (43.43)

All dimensions in inches (millimeters in parenthesis)

PANEL THICKNESS

AL00 - WALL MOUNT RECEPTACLE
Rear Mount .125" (3.18) Max

AL07 - JAM NUT RECEPTACLE
.125" (3.18) Max/.062" (1.57) Min

All dimensions in inches (millimeters in parenthesis)

DUMMY RECEPTACLES, DUST CAPS & PLUG CAPS



Example
C10-630910-09F
C10-630910-009

Example
C10-630911-09F
C10-630911-009

Example
C10-630912-09F
C10-630912-009

Example
C10-630907-09F
C10-630907-009

Example
C10-630908-09F
C10-630908-009

Example
C10-630909-09F
C10-630909-009

PLUG DUST CAPS		RECEPTACLE DUST CAPS			
Nylon braid	Nylon braid with metal ring attached	No cord	Nylon braid	Nylon braid 6-inch long with metal ring attached	Nylon braid 3.5-inch long with metal ring attached
C10-630910-XXX	C10-630911-XXX	C10-630912-XXX	C10-630907-XXX	C10-630908-XXX	C10-630909-XXX

FINISH	SUFFIX
Electroless nickel	- XXF
Black composite, unplated	- 0XX

XX = Insert shell size

CABLE CLAMPS



Straight



Right Angle

SHELL SIZE	CABLE CLAMP - ELECTROLESS NICKEL ONLY	
	STRAIGHT	RIGHT ANGLE
9	C10-630934-09F	C10-630935-09F
11	C10-630934-11F	C10-630935-11F
13	C10-630934-13F	C10-630935-13F
15	C10-630934-15F	C10-630935-15F
17	C10-630934-17F	C10-630935-17F
19	C10-630934-19F	C10-630935-19F
21	C10-630934-21F	C10-630935-21F
23	C10-630934-23F	C10-630935-23F
25	C10-630934-25F	C10-630935-25F

Metric adaptors available. Please contact us.

All dimensions in inches (millimeters in parenthesis)

WIRE STRIPPING

Strip insulation from end of wire to be crimped. See table for proper stripping dimensions. Do not cut or damage wire strands.

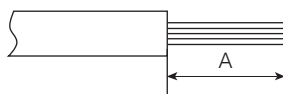

WIRE SIZE	A
22, 22M, 22D	.125 (3.18)
20	.188 (4.77)
16	.188 (4.77)
12	.188 (4.77)
10	.335 (8.51)
8 (power)	.470 (11.99)

CONTACT CRIMPING



STEP 1: Insert wire into rear of contact. Wire insulation must press against rear of contact. Wire must be visible through inspection hole.

STEP 2: M22520 series crimp tool and locator is recommended. See Contact and Tool Table on pages 244 and 245 for choice of turret head and selection setting according to contact size, part number and wire gauge size.

STEP 3: Insert contact and wire into tool jaws. To crimp, squeeze handles together fully until ratchet releases and allows handles to expand; otherwise, contact cannot be extracted from tool jaws. Maintain slight insertion pressure on wire while crimping contact to wire.

CONTACT INSERTION



STEP 1: Remove hardware from plug or receptacle and slip over wire bundle in proper order for reassembly.



STEP 2: Using proper plastic or metal insertion tool for corresponding contact, position wire in tip of the tool so that the tool tip presses against the contact shoulder.

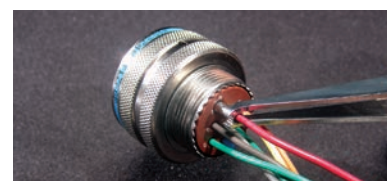

STEP 3: Press tool against contact shoulder and, with firm and even pressure, insert wired contact and tool tip into center contact cavity.

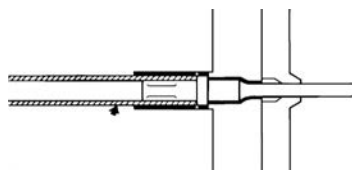

STEP 4: When contact bottoms, a slight "click" can be heard as tines of metal retaining clip snap into place behind contact shoulder.



STEP 5: Remove tool and pull back lightly on wire to make sure contact is properly seated. Repeat operation with remainder of contacts to be inserted, beginning with the center cavity and working outward in alternating rows.



STEP 6: After all contacts are inserted, fill any empty cavities with wire sealing plugs. Reassemble plug or receptacle hardware.

CONTACT EXTRACTION



STEP 1: Remove hardware from plug or receptacle and slide hardware back along wire bundle.

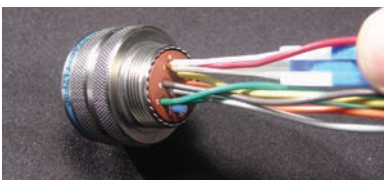

STEP 2: Using plastic or metal extraction tool with proper color code corresponding to contact size, place wire in tool.

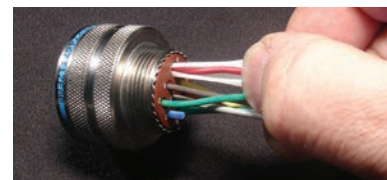

STEP 3: Insert tool into contact cavity until tool tip bottoms against the contact shoulder, expanding clip retaining tines.

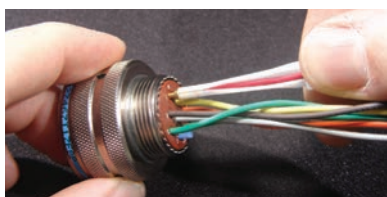

STEP 4: Hold wire firmly in tool and extract wired contact and tool. Repeat operation for all contacts to be extracted.



STEP 5: Fill any empty cavities with wire sealing plugs. Reassemble plug or receptacle hardware.

Note: LJT Series shown.

All dimensions in inches (millimeters in parenthesis)